

NeuroTrac™



Electrode Placement Manual

Visit our website: www.VerityMedical.co.uk for
detailed application protocols

VML **VERITY**
MEDICAL LTD



Contents

Contents	Page
Introduction	4
Muscle profile	4
Classification of the various types of muscular fibres	5
Hows does the muscle contract	5
Red muscle fibre type 1	8
White muscle F.O.G fibre type IIa	8
White muscle F.O.G fibre type IIb	9
Type II _m fibres	9
Limitations of the present fibre classifications	9
Muscle fibre distribution	10
Muscle Profile (trained muscle)	11
Types of muscle fibres	11
Selection of parameters	12
Pulse width selection	13
Channel selection	13
Work / Rest selection	13
Selection of electrode sizes	14
Electrode placement	15
Abdominals	15
Bieast	16
Intestinal tension	16
Waist line shaping	17
Pectorials	17
Relaxation	18
Deltoids	18
Neck	19
Upper back	19
Shoulders	20
Latimus dorsi	20
Trapezius	21
Lower back	21
Erector spinalis	22
Elbows	22



Contents	Page
Triceps	23
Biceps	23
Extensor of the wrist	24
Flexor of the wrist	24
Wrist	25
Hand regeneration	26
Hand stimulation	27
Back & legs	28
Gluteus	28
Adductors	29
Inner thigh	29
Outside thigh	30
Femoral biceps	30
Ham strings	31
Quadriceps	31
Fluid tension	32
Inner knee	32
Calves	33
Tibialis anterior	33
Peroneus	34
Knee	34
Ankle malaize	35
Ankles	35
Metataraus	36
Feet regeneration	37
Feet stimulation	38
Sole of foot	39
Heel	39



Introduction

It has been shown that nerves control muscle by transmitting a neurological code. This code or message occurs in two frequency ranges according to the type of muscle fibre required. Postural fibres require a tonic feeding at the rate of 10 pulses per second [Hz]. If applied for periods of approx. one hour every day, it is possible to support the essential characteristics of the muscle. Electrical stimulation can act as a life support until the normal function can be resumed. This is achieved by preserving capillary bed density, muscle bulk and the essential ability to use oxygen.

The second frequency range occurs at 30 pulses per second [Hz]. This frequency relays information to the fast muscle fibres, which supports power to muscle movement. This feeding of the muscle occurs naturally in a phasic way. Electrical stimulation treatment protocols to promote these fibres are given for much shorter periods than the slow twitch fibres.

This physiological approach to neuromuscular stimulation also requires pulses that are shaped similar to the naturally occurring nerve signals that have very brief pulse widths. By mimicking nature as accurately as possible, electrical stimulation has been used for long periods when required, without causing side effects.

Muscle profile

When the muscle receives an electrical impulse it starts to contract, whether the pulse originates from the brain or is produced by electrical stimulation. A very short electrical stimulation burst, however only produces a short contraction or “single shock” after which the muscle immediately returns to its natural shape and length when at rest. However, if the stimulation is repeated rapidly many times in succession, we observe that the effects of the contraction are additive due to the superimposition of the contraction stages and the inability of the muscle to relax. This phenomenon is called incomplete tetanus. Neither “single shock” nor incomplete tetanus is normally observed in voluntary action in humans.

However, a state of muscular contraction caused by repeated electrical stimulation of the motor nerves with a frequency sufficiently high to merge the individual shocks and make them indistinguishable from each other is called “complete tetanus” In this scenario, the muscle contracts and becomes firm due to the voltage generated within the muscle and, exerts a measurable force at its tendonous ends. Almost all-muscular contractions normally occurring in human muscle have the characteristics of a “complete tetanus.”



Classification of the various types of muscular fibres

The skeletal muscles are composed of a collection of muscular fibres and have various shapes according to the mechanical functions they are required to perform; broad differences, however, may be discovered in a histological examination of the fibres and these are strictly connected with the method by which a particular muscle is required to perform its task. Analysis of the fibres using a chemical colouration technique has revealed the presence of various different anaerobic and anaerobic enzymes and the same technique has permitted the various occurring in the activities of these enzymes to be revealed.

How does the muscle contract

Skeletal [striated] muscle is made of numerous long thin parallel filaments named muscular fibres running between tendons by means of which they are connected to the bones [see Figure 1]

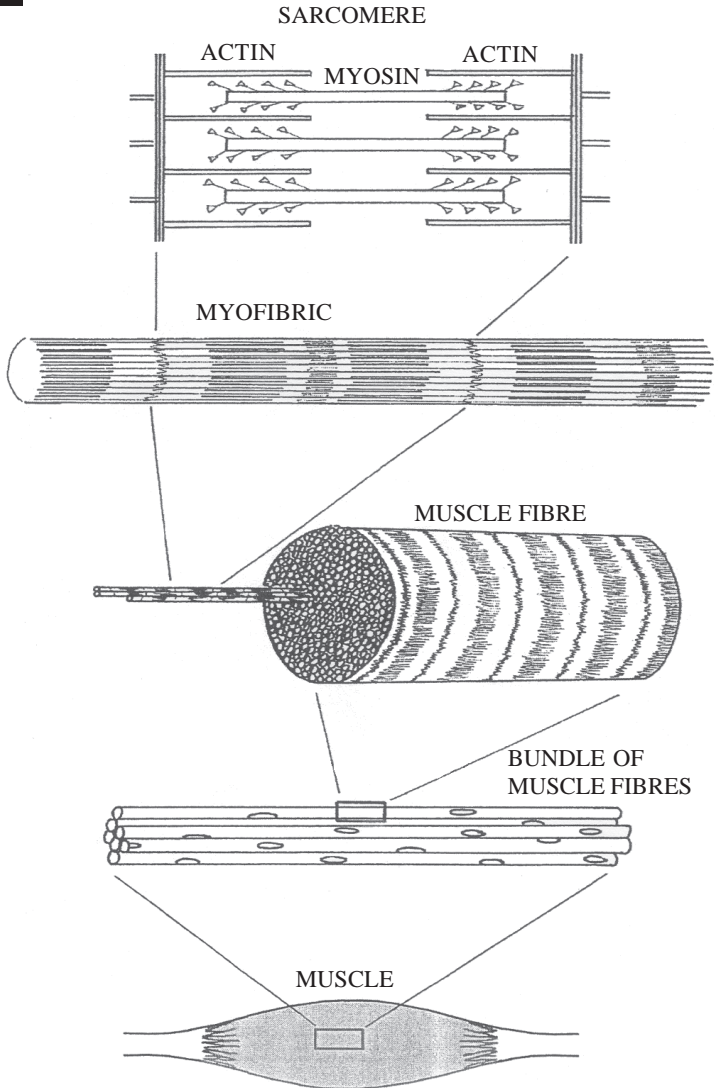

Figure 1



Muscular fibres contain bundles of filaments, surrounded by the sarcoplasmic network known as myofibril and each myofibril consists in turn of a sequence of many microscopic cylindrical elements, the sarcomeres, connected together longitudinally creating the contractile motor of the muscle. The sarcomere has a structure of cylindrical form and inside it contains thin filaments of actin that are connected at its ends [line Z] interspersed with thicker filaments of myosin {see Figure 2}

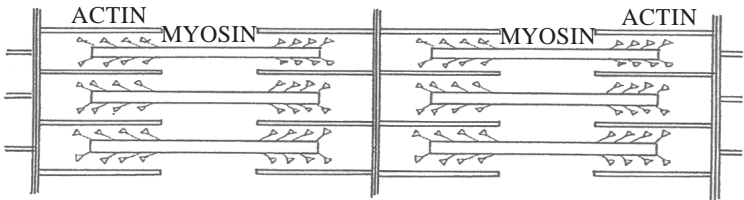

Figure 2

When an electrical impulse reaches the muscle, an activated voltage travels along the perimeter of the cellular membrane and through the system of tubes at T penetrates deeply into the muscle cell creating the release of CAE ions inside the sarcomere. The release of calcium causes attachments of specific parts of the thick filament of myosin to the thin filaments of actin and the construction of bridges between molecules {acto-myosin bridges}

The rotation that occurs on the distal portion of the bridge-head produces a sliding of the filaments between each other, which is the actual mechanism of contraction.

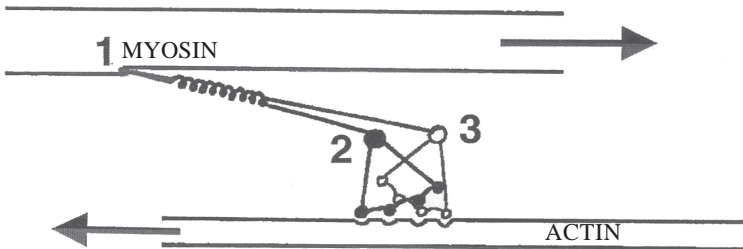

Figure 3



The rotation of the head of the myosin from position 2 to position 3 produces reciprocal motion of the filaments of actin and myosin; this mechanism is the basis of all muscular contraction. The mutual sliding produces the lines Z to approach each other and shortening of the sarcomeres, which being added to that of all the sarcomeres placed in series, generates the overall shortening of the muscle that occurs in every muscular contraction.

The filaments do not change their length when the muscle contracts, but slide between each other changing their mutual position

Red muscle fibre type 1

These type of fibres are also called ST fibres [slow contracting fibres] or SO fibres [slow fibres with oxidative metabolism]

The motor neurone that innervates them is tonic and has a low speed of conduction. Fibres of this nature are red in colour [the redness due to the presence of the myoglobin molecule]. Inside them there is a large number of mitochondria and oxidative enzymes that explains the reason why the majority of the intermitochondrial oxidative phosphorylation process take place in these fibres. A very high content of lipids and myoglobin is also associated with these metabolic functions. These type 1 muscular fibres are highly resistant to fatigue since they are responsible for all types of activities of a tonic nature, slow acting and associated with maintaining posture. These slow fibres are surrounded by a dense network of capillaries that permit optimum performance of the aerobic metabolism in a prolonged activity associated with the modest exertion of force. These red muscle fibres give the strength to the muscle and support the joint. They are fibres that are very important in all endurance sports, such as cycling, running, swimming, tennis etc.

White muscle F.O.G fibre type IIa

These are called FTa [rapid contracting fibres] fibres of FOG [rapid fibres with oxidative-glycolytic metabolism] fibres. These fibres are innervated by a phasic type motor neurone, characterised by higher speed of conduction of the tonic motor neurone. They are white in colour, due to absence of myoglobin and, are characterised by a mixed metabolic activity. These fibres are rich in glycogen and glycolytic enzymes, but also contain mitochondria enzymes; the overall metabolism is more anaerobic than the aerobic oxidative.



These fibres are also provided with a network of capillaries that carry the oxygen required for the aerobic process. Type IIa fibres are therefore, able to perform rapid contractions characterised by a significant exertion of force, which is also sustained over time giving a relative resistance [endurance] to fatigue.

White muscle fibre type IIb

These fibres are called FTb [rapid contracting fibres] fibres or FG [rapid fibres with glycolytic metabolism] fibres. This type of fibre is innervated by a phasic motor neurone with a cellular body and a very large axon that transmits pulses to the muscle at very high speed. These fibres are white to look at and have very high glycogen and glycolytic enzyme content in order to produce a very high-energy output of the anaerobic type. Contraction is fairly rapid and creates a high level of force; the almost complete absence of mitochondria renders these fibres incapable of sustaining protracted activity and therefore, easily fatigued particularly in the untrained muscle. Type IIb fibres play a very significant part in all human activities requiring the exertion of explosive force and, naturally, in all powers and explosive sports such as sprinting, weight lifting, swimming, jumping etc.

Type IIm fibres

A type of fibre that has been described with characteristics similar to those of the IIb type, but with a response to stimulation shifted to higher frequencies [approx. 100 –110 Hz]

- a) Synchronous recruitment
- b) Disinhibition approx. 30% of maximum effort
- c) The constant glycogen demands produces a more efficient replacement system.

Limitations of the present fibre classifications

The current classifications of the muscle fibres is determined more by the necessity of establishing a set of characteristics to be used for practical purposes rather than by the biological-functional reality of the human muscular system. It is assured that the fibres from part of a continuous range of various levels of metabolic organisation that are produced by the functional requirements of the various forms of human activity in general and sporting activity in particular.



Muscle fibre distribution

The fibre types as has been detailed above can be found in various percentages in muscles and the ratio between type I and type II fibres can vary considerably. Some muscle groups consist of typically type I fibres i.e. the soleus and muscles that have only type II such as the orbicular, but in the majority of cases various types of fibre are found together.

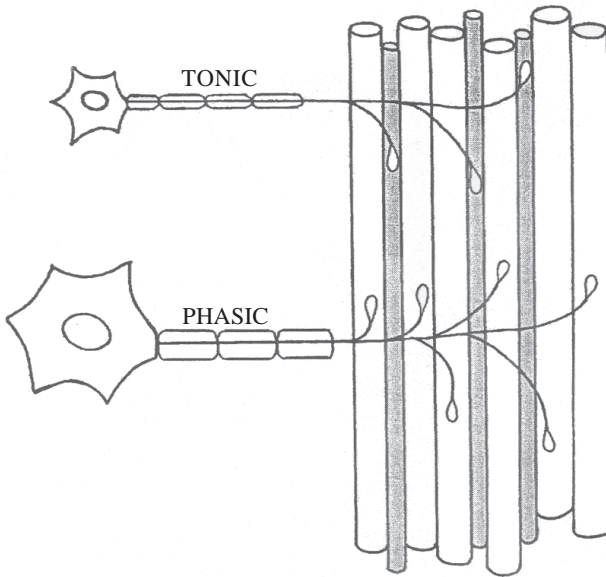

Figure 4

In figure 4 one can see the phasic and tonic fibres mixed together side by side, but the various fibres do respond to their respective motor neurones. There have been clinical studies conducted on the distribution of fibres in the muscle that have demonstrated the relationship between the motor neurone–tonic and phasic, and the functional characteristics of the fibres innervated by it and shown how a specific motor activity, in particular sporting activities can and do cause a functional adaptation of the fibres and a modification of their metabolic characteristics.



Muscle profile

[Trained Muscle]

Slow Oxidative:

[SO]

Increase in size of existing fibres
Increase in number of red fibres
Increase in size of mitochondria.
Increase in oxidative enzymes

Fast Oxidative Glycolytic

[FOG]

Posses glycolytic and oxidative metabolic pathways. Early onset of fatigue is prevented by the development of F.O.G fibres which work long periods without fatigue.

Fast Glycolytic

[FG]

Local muscle glycogen stores are depleted with 10-15 rhythmical contractions.
[Hirsch ET AL 1970]

Types of muscle fibres

Motor unit	Motor neurone	Type of metabolism	Type of muscle contraction	Muscle figure types	Frequency range of stimulation
Tonic	Low speed of conduction	SO Slow Oxidative	ST Slow Contraction	Ia	10 - 40 Hz
Phasic	Medium speed of conduction	FOG Fast Oxidative Glycolytic	FTa Rapid Contraction	IIa	50 - 70 Hz
Phasic	High speed of conduction	FG Fast Glycolytic	FTb Rapid Contraction	IIb	70 - 100 Hz
Phasic	High speed of conduction	FG Fast Glycolytic	FTm Rapid Contraction	IIm	100 - 120 Hz



Selection of parameters

Frequency selection

5 pps or below: - To introduce the stimulus to a nerve muscle situation that may not respond immediately or may not have function for a period of months or even years.

For example: 3pps is used as an introductory frequency for the electrical stimulation of spasticity. This frequency is a gentle introduction to treatment unlikely to cause spasms. 3pps is within the frequency range for the production of endorphins for pain relief and general relaxation and it is the natural firing frequency of the fusimotor pathways, which control the muscle spindles and initiate the movement sequence.

5 - 15pps This frequency range is selected to improve muscle tone, improve joint support and stability. 10pps are the natural frequency of the slow oxidative muscle fibres. Electrical stimulation will improve the muscle fatigue resistance by improving its capillary bed density and improve the muscle to handle oxygen breakdown. This frequency range may be used for extended periods of several hours per day for sports and related treatment and shorter periods for areas such as Continence.

15 - 20pps These frequencies may be used to promote endurance in the muscle. This frequency range is the natural band for the fast oxidative glycolytic muscle fibres. Treatment in this frequency band may be used up to 1 hour per day.

30 - 50 pps These frequencies are selected for strengthening a muscle and recruiting the fast glycolytic muscle fibres. Treatment using this frequency band would be for short periods only as fatiguing a muscle takes only a few minutes with electrical stimulation.

50 - 120pps These frequencies are usually selected where great power/speed and strengthening of the muscle is required. When stimulating at these high frequencies it is important that it is only for very short periods.

pps = pulses per second



Pulse width selection

The selection of pulse width is made according to the depth of penetration required for the treatment. The shorter the pulse width the more comfortable and superficial the treatment received.

Pulse width examples: Superficial muscles of the face - 70 - 80 μ S
[No higher] use low frequencies below 20Hz

Superficial muscles of the hand -	70 - 90 μ S
Muscles of the leg -	200 - 350 μ S
Muscle of the arm -	150 - 300 μ S
Pelvic or Anal muscles -	75 - 250 μ S

Channel selection

Most muscle stimulators have alternating or synchronous modes, which allows for the reproduction of agonist / antagonist activity around the joint. The alternating option should always be considered, as it will prevent the problems associated with muscle imbalance. Also inputting a delay time between the change over from one channel to another may assist voluntary movement.

The synchronous channel mode allows for the reproduction of synergic muscle activity. This is useful for functional activities accompanying specific physiotherapy programmes.

Work / Rest Selection

The rest cycle should under most circumstance be as long as the work cycle to allow the reactive hyperaemia to disperse.

If the frequency and current is raised to a level to induce a tetanic contraction it may be more appropriate to enlist a longer rest cycle to allow a movement to occur. One would expect the patient to produce voluntary movement [contraction] during the rest cycle.

Example 4 secs on 4 secs off - **increase rest time to between 6 –8 seconds or more.**



Selection of electrode sizes

The size of electrode to be used depends largely on the pulse width to be used and, which part of the body the electrode is to be placed upon. Generally the wider the pulse width and the higher the mA current to be used the larger the electrode needs to be.

For the face, fingers and hands where the muscle is superficial the pulse width should be kept down to below 90 μ S, allowing a smaller surface area electrode to be used normally 26 to 30mm diameter.

For the arm, lower parts of the leg and ankle the pulse width selection ideally should be below 300 μ S allowing the surface area electrode to be more than when used on superficial muscles of approx. 40 to 50mm square.

For the quads, upper arm, lower, upper back and gluteus maximus the pulse width ideally should be 350 μ S or below. The muscle mass is larger in these areas that allows larger surface area of electrode to be used. 50 x 50 or 50 x 100 being the most common sizes, although larger surface area electrodes can be used.



Electrode placement

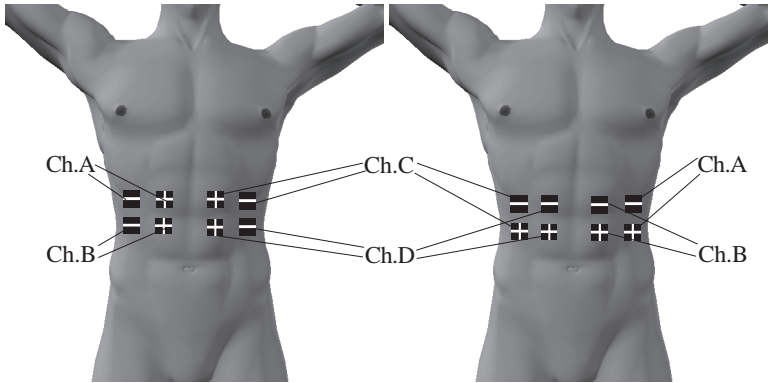

Abdominals 1

Suggested Settings

Electrode Size: 50 x 50 mm

Pulse Width: 250 μ S

Abdominals 2

Suggested Settings

Electrode Size: 50 x 50 mm

Pulse Width: 250 μ S

Positive  Red must be placed on the motor point of the muscle. Find the best position by slightly moving the positive electrode around.

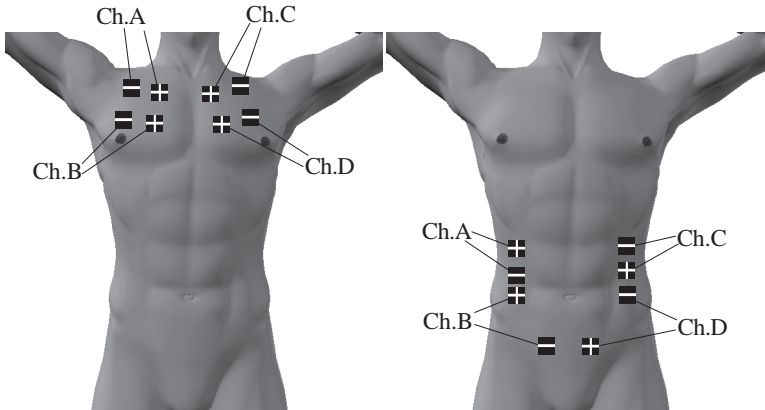

Bieast

Suggested Settings

Electrode Size: 50 x 50 mm
Pulse Width: 220 - 250 μ S

Intestinal tension

Suggested Settings

Electrode Size: 50 x 50 mm
Pulse Width: 220 - 250 μ S

Positive  Red must be placed on the motor point of the muscle. Find the best position by slightly moving the positive electrode around.

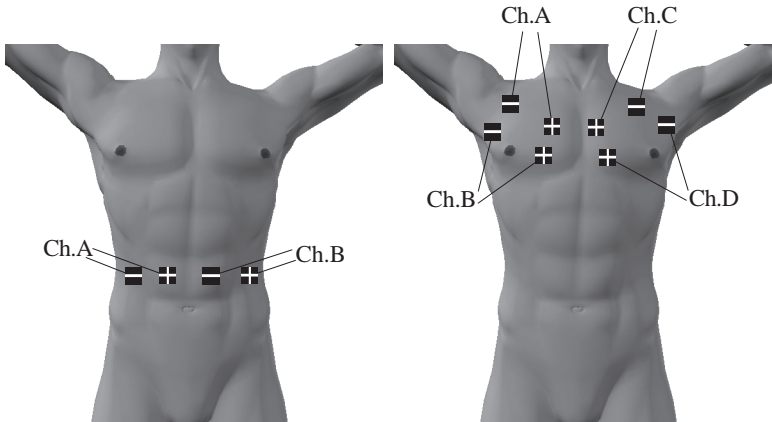

Waist line shaping

Suggested Settings

Electrode Size: 50 x 50 mm
Pulse Width: 220 - 250 μ S

Pectorials

Suggested Settings

Electrode Size: 50 x 50 mm
Pulse Width: 220 - 275 μ S

Positive  Red must be placed on the motor point of the muscle. Find the best position by slightly moving the positive electrode around.

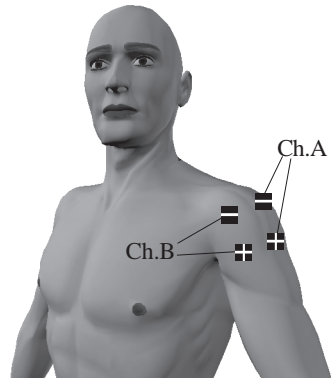
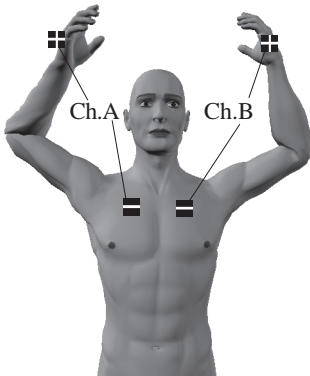

Relaxation

Suggested Settings

Electrode Size: 50 x 50 mm
Pulse Width: 220 - 250 μ S

Deltoids

Suggested Settings

Electrode Size: 50 x 50 mm
Pulse Width: 220 - 250 μ S

Positive  Red must be placed on the motor point of the muscle. Find the best position by slightly moving the positive electrode around.

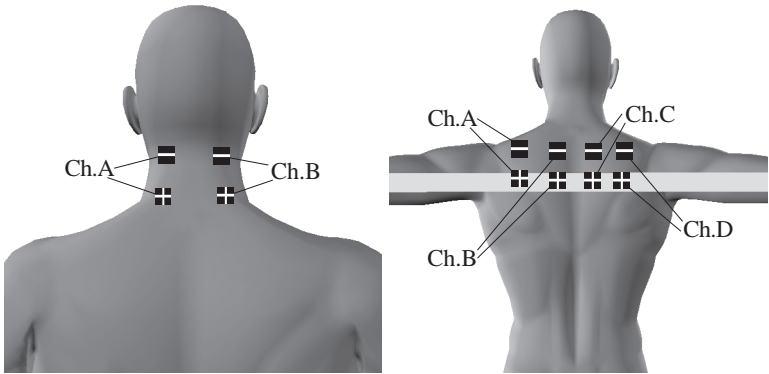

Neck

Suggested Settings

Electrode Size: 50 x 50 mm
(Max size) or 30 mm dia
Pulse Width: 220 - 250 μ S

Upper back

Suggested Settings

Electrode Size: 50 x 50 mm
Pulse Width: 220 - 250 μ S

Positive  Red must be placed on the motor point of the muscle. Find the best position by slightly moving the positive electrode around.

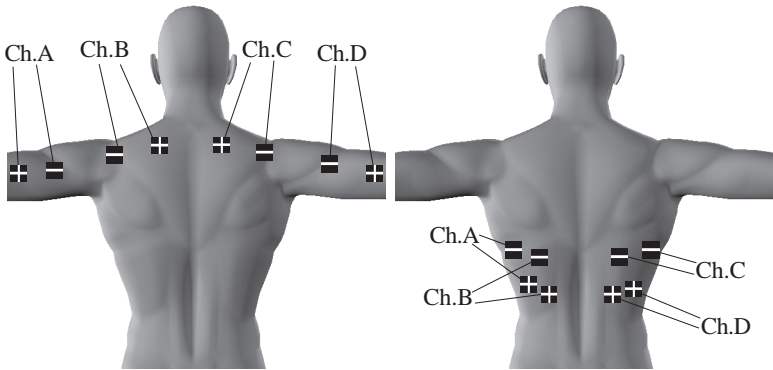

Shoulders

Suggested Settings

Electrode Size: 50 x 50 mm
Pulse Width: 220 - 250 μ S

Latimus Dorsi

Suggested Settings

Electrode Size: 50 x 50 mm
or
50 x 100 mm
Pulse Width: 250 - 275 μ S

Positive  Red must be placed on the motor point of the muscle. Find the best position by slightly moving the positive electrode around.

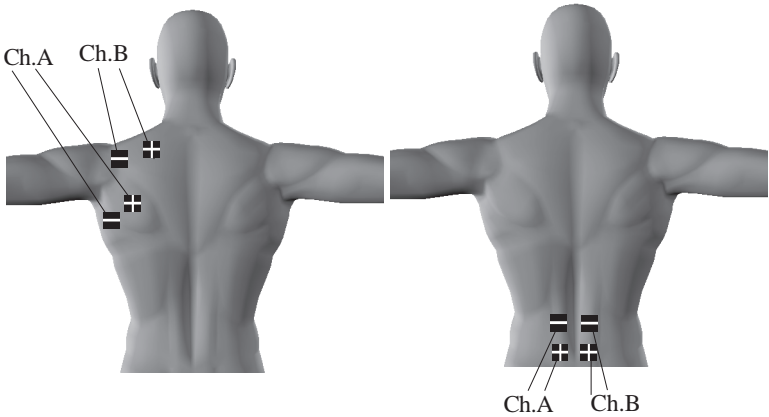

Trapezius

Suggested Settings

Electrode Size:

Shoulders 50 x 50 mm
Back 50 x 50 mm
or
 50 x 100 mm
Pulse Width: 220 - 250 μ S

Lower back

Suggested Settings

Electrode Size: 50 x 50 mm
Pulse Width: 220 - 250 μ S

Positive  Red must be placed on the motor point of the muscle. Find the best position by slightly moving the positive electrode around.

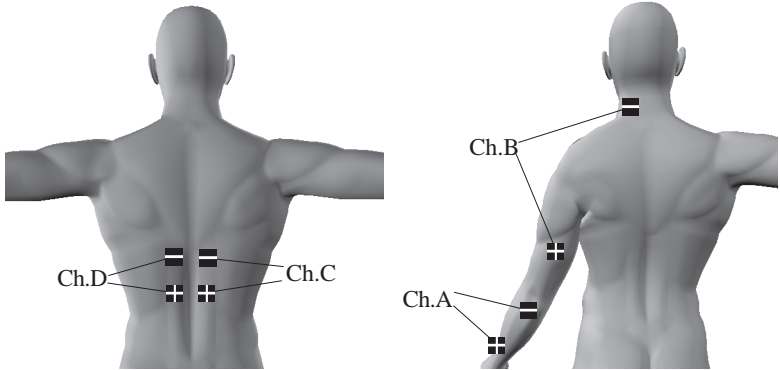

Erector spinalis

Suggested Settings

Electrode Size: 50 x 50 mm
Pulse Width: 220 - 250 μ S

Elbows

Suggested Settings

Electrode Size: 50 x 50 mm
Pulse Width: 220 - 250 μ S

Positive  Red must be placed on the motor point of the muscle. Find the best position by slightly moving the positive electrode around.

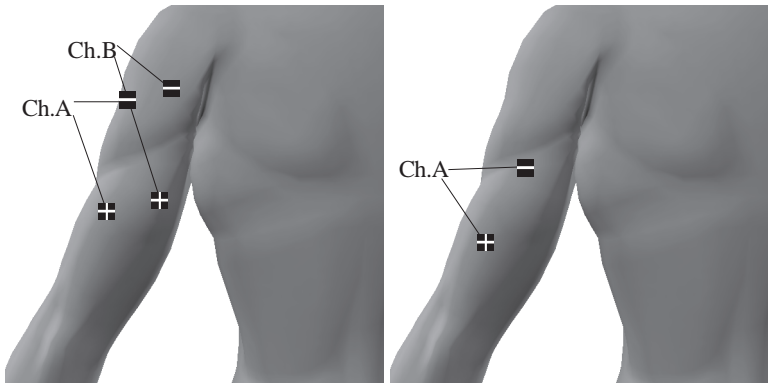

Triceps

Suggested Settings

Electrode Size: 50 x 50 mm
Pulse Width: 220 - 250 μ S

Biceps

Suggested Settings

Electrode Size: 50 x 50 mm
Pulse Width: 220 - 250 μ S

Positive  Red must be placed on the motor point of the muscle. Find the best position by slightly moving the positive electrode around.

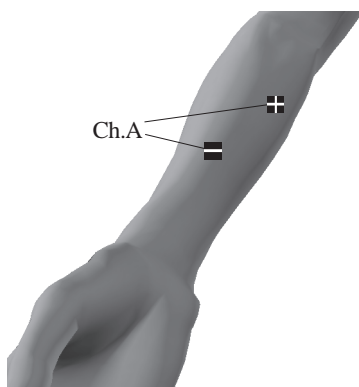
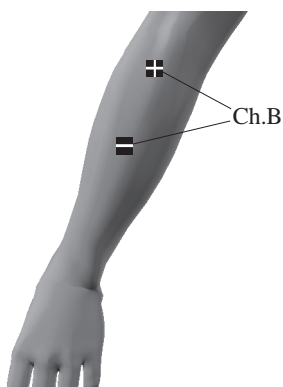

Extensor of the wrist

Suggested Settings

Electrode Size: 50 x 50 mm

Pulse Width: 220 μ S

Flexor of the wrist

Suggested Settings

Electrode Size: 50 x 50 mm

Pulse Width: 220 μ S

Positive  Red must be placed on the motor point of the muscle. Find the best position by slightly moving the positive electrode around.

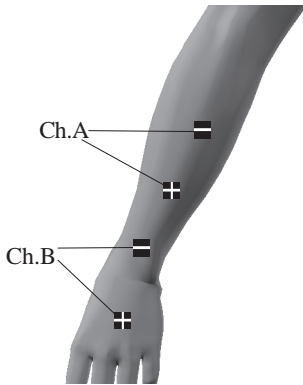

Wrist

Suggested Settings

Electrode Size: 50 x 50 mm
or
30 mm dia
Pulse Width: 220 μ S

Positive  Red must be placed on the motor point of the muscle. Find the best position by slightly moving the positive electrode around.

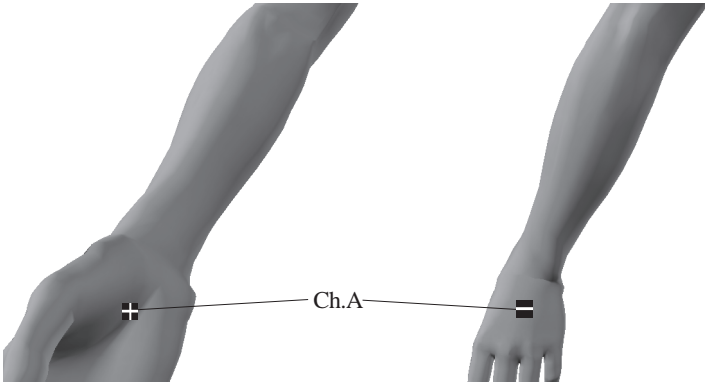

Hand regeneration

Suggested Settings

Electrode Size: 50 x 50 mm
or
30 mm dia
Pulse Width: 200 μ S

Positive  Red must be placed on the motor point of the muscle. Find the best position by slightly moving the positive electrode around.

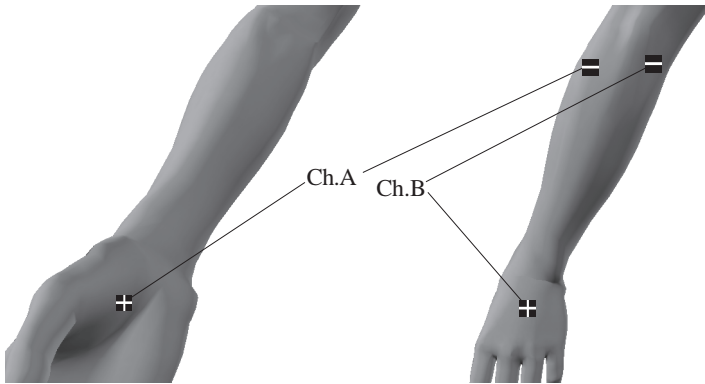

Hand stimulation

Suggested Settings

Electrode Size: 50 x 50 mm
or
30 mm dia
Pulse Width: 200 μ S

Positive  Red must be placed on the motor point of the muscle. Find the best position by slightly moving the positive electrode around.

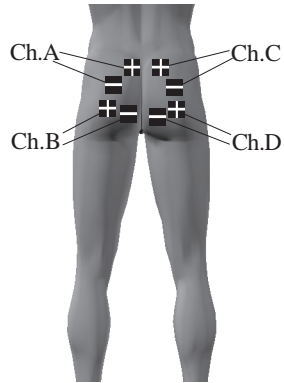
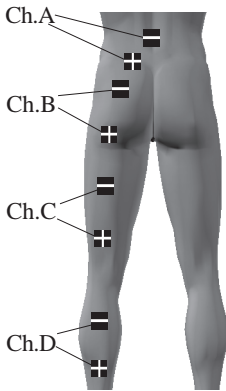

Back & legs

Suggested Settings

Electrode Size: 50 x 50 mm
Pulse Width: 220 - 300 μ S

Gluteus

Suggested Settings

Electrode Size: 50 x 50 mm
Pulse Width: 250 - 300 μ S

Positive  Red must be placed on the motor point of the muscle. Find the best position by slightly moving the positive electrode around.

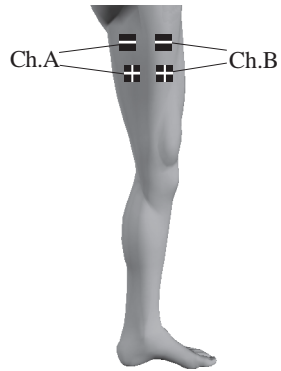
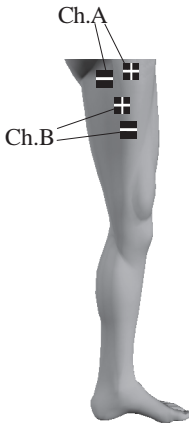

Adductors

Suggested Settings

Electrode Size: 50 x 50 mm
Pulse Width: 250 - 300 μ S

Inner thigh

Suggested Settings

Electrode Size: 50 x 50 mm
or
50 x 100 mm
Pulse Width: 250 - 300 μ S

Positive  Red must be placed on the motor point of the muscle. Find the best position by slightly moving the positive electrode around.

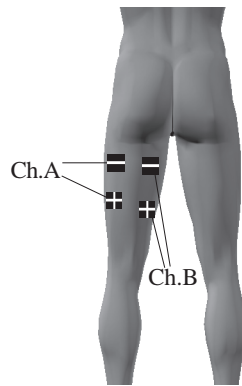

Outside thigh

Suggested Settings

Electrode Size: 50 x 50 mm
or
50 x 100 mm
Pulse Width: 250 - 300 μ S

Femoral biceps

Suggested Settings

Electrode Size: 50 x 50 mm
or
50 x 100 mm
Pulse Width: 220 - 250 μ S

Positive  Red must be placed on the motor point of the muscle. Find the best position by slightly moving the positive electrode around.

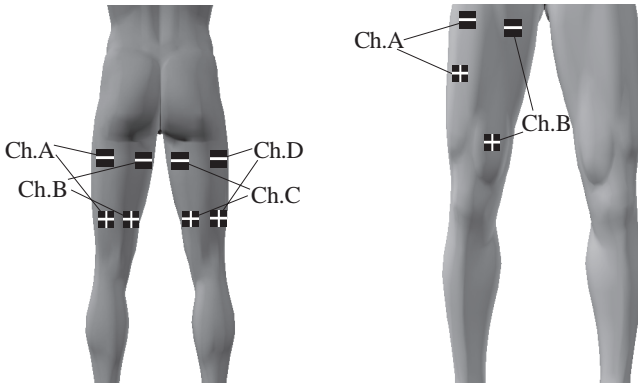

Ham strings

Suggested Settings

Electrode Size: 50 x 50 mm
Pulse Width: 250 - 300 μ S

Quadriceps

Suggested Settings

Electrode Size: 50 x 50 mm
or
50 x 100 mm
Pulse Width: 250 -300 μ S

Positive  Red must be placed on the motor point of the muscle. Find the best position by slightly moving the positive electrode around.

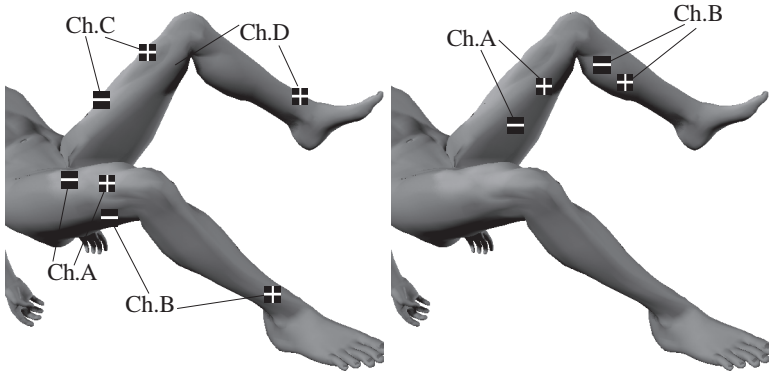

Fluid tension

Suggested Settings

Electrode Size:

Upper Leg 50 x 50 mm
or 50 x 100 mm

Ankle 50 x 50 mm

Pulse Width: 220 - 275 μ S

Inner knee

Suggested Settings

Electrode Size: 50 x 50 mm

Pulse Width: 250 - 300 μ S

Please Note:

Ch.C & Ch.D positions on the left leg
are identical to the Ch.A & Ch.B
positions on the right leg.

The - electrode for Ch.D is not visible
on this picture

Positive \oplus Red must be placed on the motor point of the muscle. Find the best
position by slightly moving the positive electrode around.

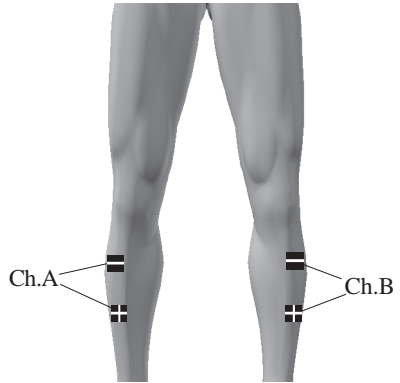

Calves

Suggested Settings

Electrode Size: 50 x 50 mm
Pulse Width: 220 - 275 μ S

Tibialis anterior

Suggested Settings

Electrode Size: 50 x 50 mm
Pulse Width: 220 - 250 μ S

Positive  Red must be placed on the motor point of the muscle. Find the best position by slightly moving the positive electrode around.

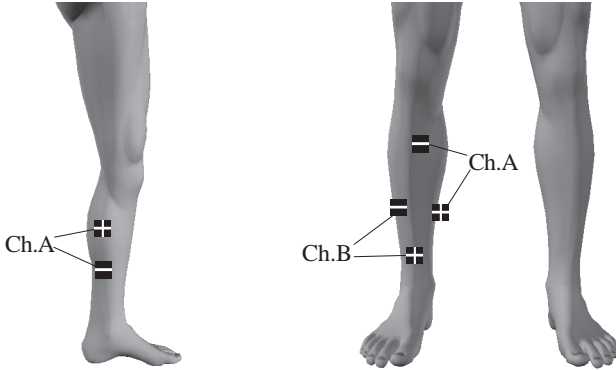

Peroneus

Suggested Settings

Electrode Size: 50 x 50 mm
Pulse Width: 220 - 275 μ S

Knee

Suggested Settings

Electrode Size: 50 x 50 mm
Pulse Width: 220 - 250 μ S

Positive  Red must be placed on the motor point of the muscle. Find the best position by slightly moving the positive electrode around.

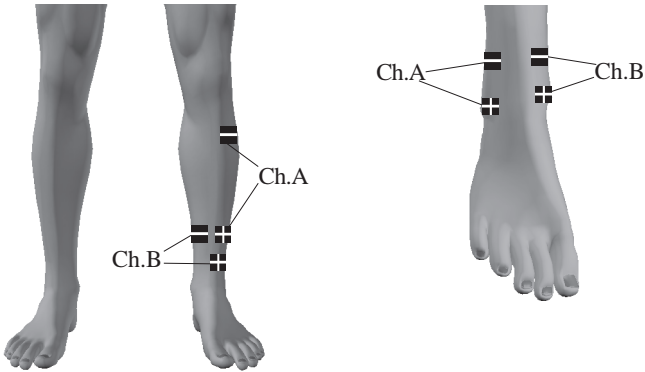

Ankle malaize

Suggested Settings

Electrode Size: 50 x 50 mm
Pulse Width: 220 - 250 μ S

Ankles

Suggested Settings

Electrode Size: 50 x 50 mm
Pulse Width: 220 μ S

Positive  Red must be placed on the motor point of the muscle. Find the best position by slightly moving the positive electrode around.



+ = **Red**

- = **Black**

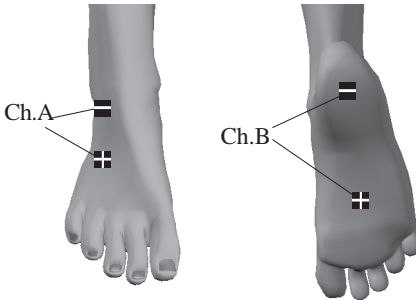

Metatarsus

Suggested Settings

Electrode Size: 50 x 50 mm
Pulse Width: 220 - 250 μ S

Positive \oplus Red must be placed on the motor point of the muscle. Find the best position by slightly moving the positive electrode around.

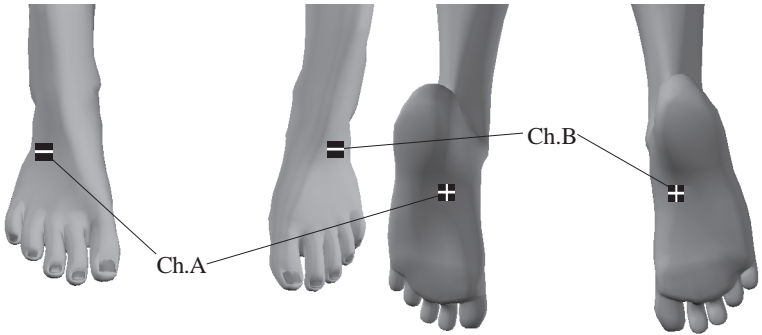

Feet regeneration

Suggested Settings

Electrode Size: 50 x 50 mm

Pulse Width: 220 μ S

Positive  Red must be placed on the motor point of the muscle. Find the best position by slightly moving the positive electrode around.



+ = **Red**
- = **Black**

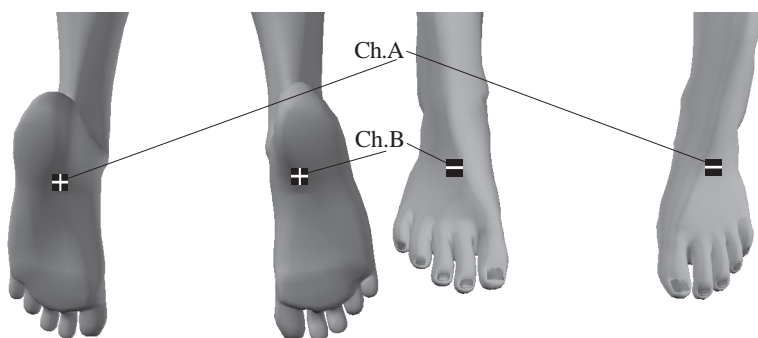

Feet stimulation

Suggested Settings

Electrode Size: 50 x 50 mm
Pulse Width: 220 μ S

Please note: Ch.A + & - electrodes are placed on the left foot. Ch.B + & - electrodes are placed on the right foot.

Positive  Red must be placed on the motor point of the muscle. Find the best position by slightly moving the positive electrode around.

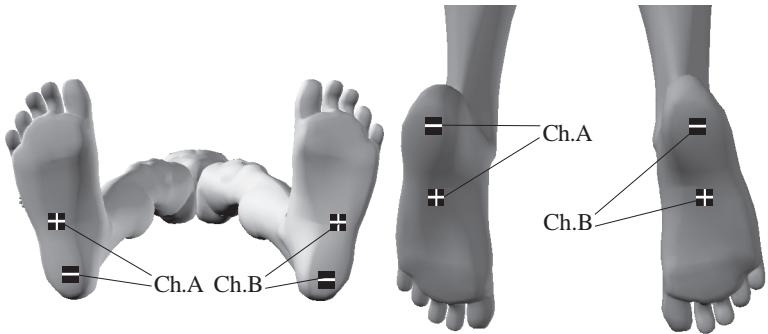

Sole of foot

Suggested Settings

Electrode Size: 50 x 50 mm
Pulse Width: 220 μ S

Heel

Suggested Settings

Electrode Size: 50 x 50 mm
or
30 mm dia
Pulse Width: 220 μ S

Positive \oplus Red must be placed on the motor point of the muscle. Find the best position by slightly moving the positive electrode around.

Not for sale or use in the USA



Ehrhardt & Rieke GbR

Unterm Königshof 40 | 34346 Hann. Münden

Tel.: +49 (0) 5541-9992030 | Fax: +49 (0) 5541-660909

Internet: www.tens4you.de | Email: info@tens4you.de

VM **VERITY**
MEDICAL LTD

Uplands Place
Drove Road
Chilbolton
Nr Stockbridge
Hampshire SO20 6AD
England

Tele: +44 (0)1264 860354

Fax: +44 (0)1264 860825

Email: Sales@VerityMedical.co.uk

Web: www.VerityMedical.co.uk
